

PRODUCT DIMENSION						SIZE SELECTION					
SIZE	THICKNESS		INTERNAL HEIGHT (H)			PIPE		HEP		BOX SPAN	
	WT	ST	MIN	INTV.	MAX	LONG / SHORT WALL	LONG / SHORT WALL	LONG / SHORT WALL	LONG / SHORT WALL	LONG / SHORT WALL	
L X W	WT	ST	MIN	INTV.	MAX	STRAIGHT	45° ANGLED	STRAIGHT	45° ANGLED	STRAIGHT	45° ANGLED
2438 X 1829	NOTE (18)	203	914	152	2438	1800 / 1200	1200 / 825	1500 / 1050	900 / NA	1800 / NA	NA
3048 X 1829	254	254	610	152	2438	2400 / 1200	1500 / 825	1950 / 1050	1200 / NA	2400 / NA	NA
3048 X 2438	203	254	610	152	2438	2400 / 1500	1500 / 1050	1950 / 1500	1200 / 900	2400 / 1800	NA
3962 X 2438	254	305	610	152	2438	3000 / 1800	1950 / 1050	2400 / 1500	1650 / 900	3000 / 1800	1800 / NA
3962 X 3048	254	305	610	152	2438	3000 / 2400	1950 / 1500	2400 / 1950	1650 / 1200	3000 / 2400	1800 / NA

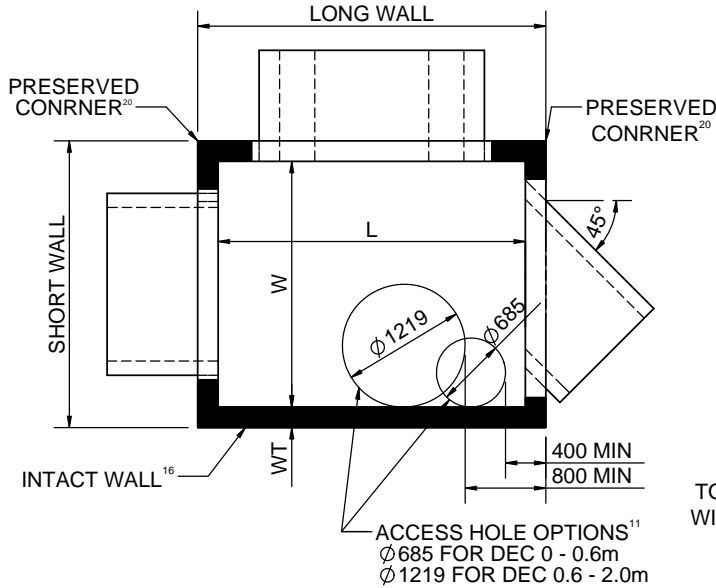

SECTION PLAN VIEW

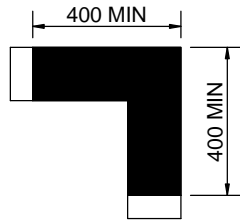

PRESERVED CORNER

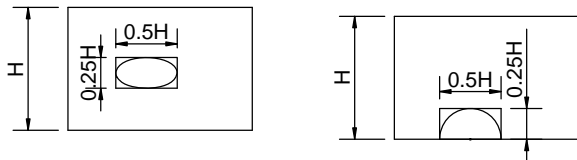

MAX ALLOWABLE OPENING ON INTACT WALL

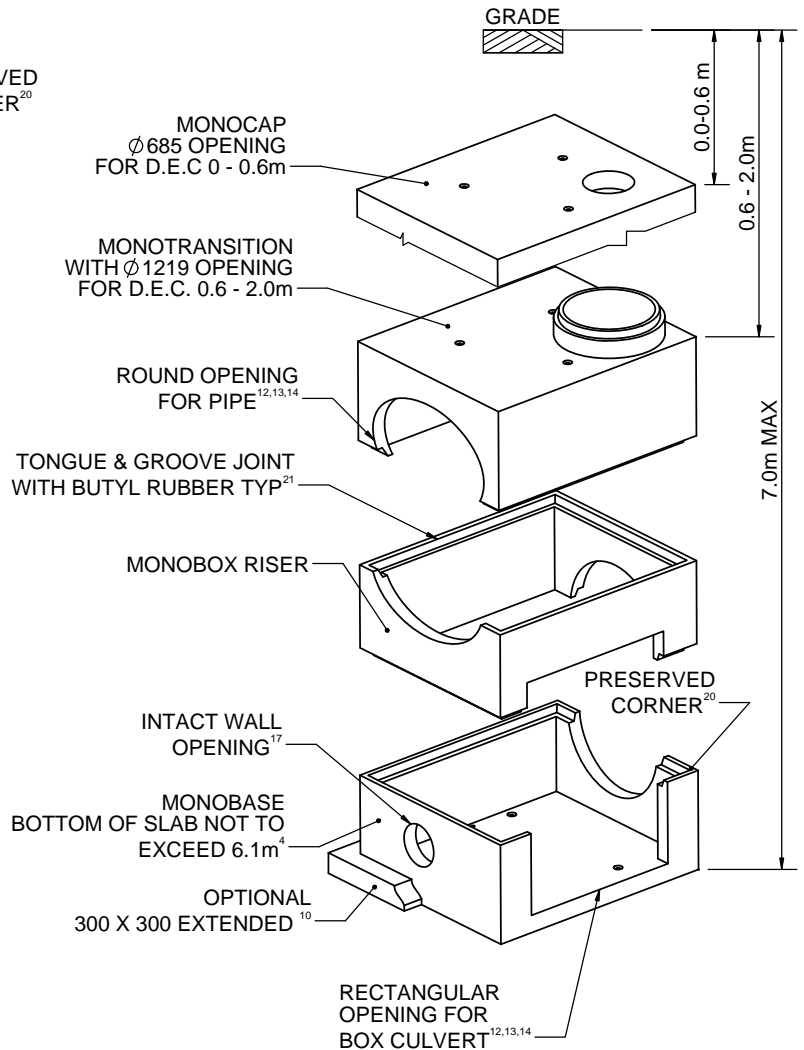

ISOMETRIC VIEW

ALL DIMENSIONS ARE IN mm
DRAWINGS ARE NOT TO SCALE

CON CAST PIPE (CCP) STANDARD DRAWING

STD. CCP ENG GUIDE B.8.1.3 PART MONOBOX-GUIDE

TITLE
**MONOBOX - MANHOLE APPLICATION
DESIGN GUIDE
EARTH COVER 2.0m MAX
BURIED DEPTH 7.0m MAX**

4	JOINT UPDATE, HEIGHT UPDATE	SW	22MAY2015
3	MODIFY TO 2012 GAMSBY DESIGN	SW	1MAY2014
2	MAX PIPE SIZE CORRECTION	CW	16DEC11
REV.	DESCRIPTION	ENG.	DATE

DRAWN BY SW	CHECKED BY CHKD BY	DATE 6MAR14	FILE MONOBOX Rev4	PAGE 1 OF 2
----------------	-----------------------	----------------	----------------------	----------------

GENERAL NOTES:

DESIGN CRITERIA

- DESIGN TO CSA S6-06 CHBDC ONT625 LOADING. CUSTOM DESIGN IS AVAILABLE FOR ALL OTHER LOADING: AREMA, AIRCRAFT ETC.
- DESIGN EARTH COVER 0 - 2.0m TO THE TOP OF THE SLAB
- MAXIMUM BURIED DEPTH 6.1m FOR STANDARD DESIGN. UP TO 13.0m BURIED DEPTH WITH INCREASED SLAB / WALL THICKNESS. OVER 13.0m BURIED DEPTH REQUIRED DESIGN ASSESSMENT TO CONFIRM THE GEOMETRY.
- MAXIMUM DESIGN EARTH COVER IS 2.0m FOR STANDARD DESIGN. UP TO 4.0m EARTH COVER WITH ADDITIONAL REINFORCING STEEL. OVER 4.0m EARTH COVER MAY REQUIRE THICKER SLAB THICKNESS. DESIGN ASSESSMENT IS REQUIRED TO CONFIRM THE GEOMETRY.

CONCRETE

- MINIMUM CONCRETE STRENGTH 40MPa.

REINFORCING STEEL

- REINFORCING STEEL CONFORMS TO THE FOLLOWING LATEST CSA OR ASTM STANDARDS:
 - ASTM A185 WELDED STEEL WIRE FABRIC FOR CONCRETE REINFORCEMENT
 - ASTM A497 WELDED DEFORMED STEEL WIRE FABRIC FOR CONCRETE REINFORCEMENT
 - CSA W186-M WELDING OF REINFORCING BARS IN REINFORCED CONCRETE CONSTRUCTION
 - CSA G30.18-M DEFORMED REINFORCING BARS SHALL BE 400W PER LATEST
- CLEAR COVER TO REINFORCING STEEL
 - MESH: 40 mm +/- 5 mm
 - REBAR: 50 mm +/- 10 mm

INSTALLATION

- BACKFILL AND COMPACTION TO OWNER'S REQUIREMENT
- RESPONSIBILITY FOR CONSTRUCTION REVIEW, ADEQUACY, AND SUITABILITY OF EXCAVATION, DEWATERING, SHORING, HANDLING EQUIPMENT, AND SOIL STABILITY BY OTHERS

BUOYANCY

- WHEN APPLICABLE, 300 X 300 EXTENDED BASE IS REQUIRED WHEN THE SUM OF WATER TABLE TO GRADE AND TOP OF THE SLAB TO GRADE IS GREATER THAN 2.2m.

DESIGN CONSIDERATION

- SLAB OPENING: $\phi 685$ OR $\phi 1219$. LARGER OPENING OR RECTANGULAR OPENING MAY BE ACCOMMODATED.
- WALL OPENING IN MONOBASE: MAXIMUM WIDTH CAN BE THE INSIDE WIDTH OF THE WALL; MAXIMUM HEIGHT CAN BE THE INSIDE HEIGHT OF THE WALL
- WALL OPENING IN MONOTOP, MONOTRANSITION, AND RISER: MAXIMUM WIDTH CAN BE THE INSIDE WIDTH OF THE WALL; MAXIMUM HEIGHT CAN BE THE INSIDE HEIGHT OF THE WALL LESS 500.
- WALL OPENING DEFINED IN (11) AND (12) MAY BE IN ANY OR ALL THREE WALLS OF THE COMPONENTS
- OPENING IN ADJACENT WALL: MINIMUM 400 X 400 PRESERVED CORNER MUST BE MAINTAINED.
- MINIMUM ONE INTACT WALL PER COMPONENT
- INTACT WALL MAY HAVE AN OPENING OR MULTIPLE OPENINGS WITH OVERALL HEIGHT NO LARGER THAN 0.25 TIMES INSIDE HEIGHT OF THE COMPONENT AND TOTAL WIDTH NO LARGER THAN 0.5 TIMES INSIDE WIDTH OF THE COMPONENT.

OTHER DESIGN NOTES

- MONOBOX WALL THICKNESS FOR 2438 X 1829: DRY CAST 203, WET CAST 152 OR 203
- MONOBOX MUST MAINTAIN MINIMUM ONE INTACT WALL
- RESERVED CORNER OCCURS BETWEEN TWO LARGE OPENING AT ADJACENT WALLS
- MINIMUM EDGE DISTANCE FROM ACCESS HOLE W.R.T. WALL OPENING IS 400 AND 800 FOR $\phi 685$ AND $\phi 1219$ OPENINGS RESPECTIVELY.
- STANDARD MONOBOX COMPONENT HAS 102mm TONGUE/GROOVE JOINT & 40mm UNI-SEX JOINT FOR WET CAST 2438 X 1829 MONOBOX RESPECTIVELY. 25 mm BUTYL RUBBER TO BE SUPPLIED BY CON CAST PIPE AND INSTALLED ON SITE BY OTHERS. SPECIAL JOINT OR WATER PROOFING ARE AVAILABLE UPON REQUEST.
- MONOBOX STRUCTURE COMES WITH STANDARD 16" HOLLOW ALUMINUM STEP(S) CONFORMED TO OPSD405.010 SPACED AT 300. OTHER TYPE OF STEP(S) OR LADDER ARE AVAILABLE UPON REQUEST.
- CAST-IN DAYTON SUPERIOR P50 SWIFT LIFT ANCHORS OR EQUIV. ARE STANDARD DEVICE FOR HANDLING AND INSTALLATION.
- CAST-IN INSERTS FOR CAST-IN-PLACE COMPONENTS SUCH AS THRUST BLOCK ARE AVAILABLE UPON REQUEST.
- CAST-IN LIFTING HOOKS OR THREADED INSERTS FOR INTERNAL LIFTING ANCHORS ARE AVAILABLE UPON REQUEST.
- CONTACT CON CAST ENGINEERING FOR DESIGN BEYOND THE DESIGN CRITERIA AND LIMITATION LISTED IN THIS DOCUMENT

FINAL DESIGN FOR APPROVAL AND MANUFACTURING

- STANDARD REINFORCEMENT FULFILLS THE DESIGN CRITERIA.
- FINAL DESIGN OF MONOBOX INCLUDING, BUT NOT LIMITED TO, STACKING, ADDITIONAL REINFORCING, CUSTOMIZATION WILL PRESENT IN SHOP DRAWING PACKAGE.

ALL DIMENSIONS ARE IN mm DRAWINGS ARE NOT TO SCALE		CON CAST PIPE (CCP) STANDARD DRAWING					
		STD. CCP ENG GUIDE B.8.1.3				PART MONOBOX-GUIDE	
		MONOLITHIC BOX MANHOLE DESIGN GUIDE GENERAL NOTES					
4	NOTE 1, 3, 4, 22	SW	22MAY2015				
3	MODIFY TO 2012 GAMSBY DESIGN	SW	1MAY2014				
2	MAX PIPE SIZE CORRECTION	CW	16DEC11				
REV.	DESCRIPTION	ENG.	DATE	DRAWN BY SW	CHECKED BY --	DATE 22MAY15	FILE MONOBOX Rev4
						PAGE 2 OF 2	
 CONCAST RR 3 Guelph, ON N1H 6H9				Fax: (519) 763-1956		1-800-668-7473 www.concastpipe.com	

PRODUCT GEOMETRY					MAX MASS ESTIMATE (X 1000 kg)														
SIZE	WALL (W)	SLAB (S)	HAUNC	CAST ¹⁹ / JOINT ²⁰	SLAB	RISER (PER m)	INTERNAL HEIGHT (H) ⁷												
							610	762	914	1067	1219	1372	1524	1676	1829	1981	2134	2286	2438
2438 X 1829	203	203	0	DC/TG40	3.20	4.71			7.50	8.22	8.94								
2438 X 1829	152	203	0	WC-S/US40	2.94	3.45			6.09	6.62	7.15	7.67	8.20						
2438 X 1829	203 ⁵	203 ⁶	0	WC-F/TG40	3.20	4.71	6.07	6.79	7.50	8.22	8.94	9.66	10.37	11.09	11.81	12.52	13.24	13.96	14.67
3048 X 2438	203	254	0	DC/TG40	6.19	5.93			11.61	12.52	13.42								
3048 X 2438	203	254	0	WC-S/TG102	6.19	5.93			11.61	12.52	13.42	14.33	15.23	16.13	17.04				
3048 X 2438	203 ⁵	254 ⁶	0	WC-F/TG102	6.19	5.93	9.81	10.71	11.61	12.52	13.42	14.33	15.23	16.13	17.04	17.94	18.85	19.75	20.65
3048 X 1829	203 ⁵	254 ⁶	0	WC-F/TG102	4.86	5.32	8.11	8.92	9.72	10.54	11.35	12.16	12.97	13.78	14.59	15.40	16.21	17.02	17.83
3962 X 2438	254 ⁵	305 ⁶	0	WC-S/TG102	9.96	8.70			17.92	19.25	20.57	21.90	23.22	24.55	25.88	27.20	28.53		
3962 X 2438	254 ⁵	305 ⁶	0	WC-F/TG102	9.96	8.70	15.27	16.59	17.92	19.25	20.57	21.90	23.22	24.55	25.88	27.20	28.53	29.86	31.18
3962 X 3048	254 ⁵	305 ⁶	0	WC-S/TG102	12.02	9.47			20.68	22.13	23.57	25.02	26.46	27.90	29.35	30.79	32.24		
3962 X 3048	254 ⁵	305 ⁶	0	WC-F/TG102	12.02	9.47	17.80	19.24	20.68	22.13	23.57	25.02	26.46	27.90	29.35	30.79	32.24	33.68	35.11
4420 X 3048	305 ⁵	305 ⁶	8	WC-F/TG102	13.92	12.22	21.37	23.23	25.09	26.96	28.81	30.68	32.54	34.40	36.27	38.13			
5029 X 3048	305 ⁵	305 ⁶	8	WC-F/TG102	15.60	13.14	23.62	25.62	27.61	29.62	31.62	33.63	35.63	37.63	39.64				
5537 X 3810	356 ⁵	305 ⁶	8	WC-F/TG102	21.37	17.76	32.21	34.91	37.61	40.33									

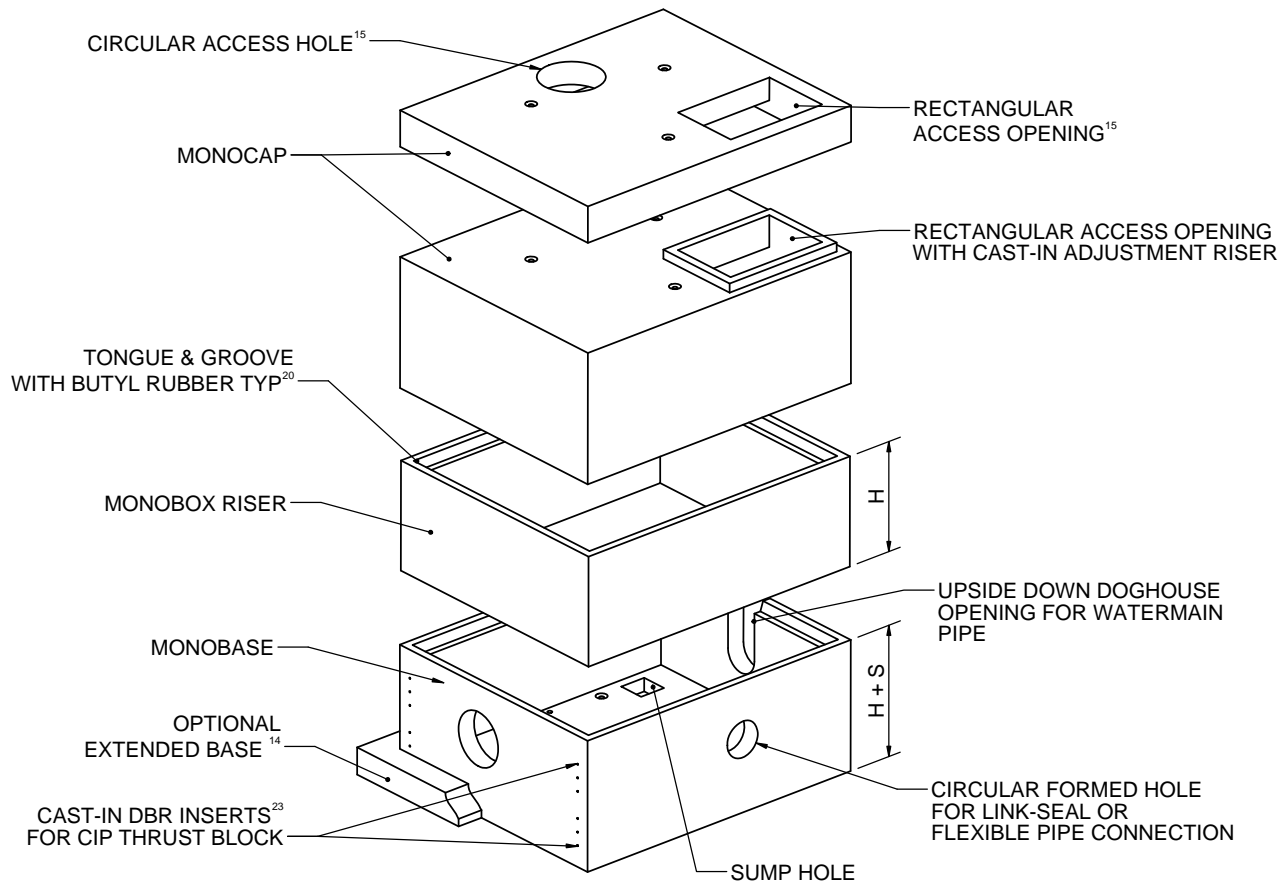

ALL DIMENSIONS ARE IN mm
DRAWINGS ARE NOT TO SCALE

CON CAST PIPE (CCP) STANDARD DRAWING

STD. CCP ENG GUIDE B.8.1.5 PART MONOBOX-GUIDE

TITLE MONOBOX - CHAMBER APPLICATION DESIGN GUIDE

3									
2	UPDATE JOINT	SW	26MAY15						
1	NEW RELEASE	SW	1MAY2014	DRAWN BY SW	CHECKED BY	DATE 6MAR14	FILE MONOBOX Rev4	PAGE 1 OF 2	
REV.	DESCRIPTION	ENG.	DATE						

GENERAL NOTES:

DESIGN CRITERIA

1. DESIGN TO CSA S6-06 CHBDC ONT625 LOADING. CUSTOM DESIGN IS AVAILABLE FOR ALL OTHER LOADING: AREMA, AIRCRAFT ETC.
2. DESIGN EARTH COVER 0 - 2.0m TO THE TOP OF SLAB
3. MAXIMUM BURIED DEPTH 6.1m FOR STANDARD DESIGN. UPTO 13.0m BURIED DEPTH WITH INCREASED SLAB / WALL THICKNESS. OVER 13.0m BURIED DEPTH REQUIRED DESIGN ASSESSMENT TO CONFIRM THE GEOMETRY.
4. MAXIMUM DESIGN EARTH COVER IS 2.0m FOR STANDARD DESIGN. UPTO 4.0m EARTH COVER WITH ADDITIONAL REINFORCING STEEL. OVER 4.0m EARTH COVER MAY REQUIRE THICKER SLAB THICKNESS. DESIGN ASSESSMENT IS REQUIRED TO CONFIRM THE GEOMETRY.

GEOMETRY

5. WALL THICKNESSES SHOWN IN TABLE ARE STANDARD FOR THE ABOVE DESIGN CRITERIA. THICKER WALL IS AVAILABLE FOR DEEPER STRUCTURE.
6. SLAB THICKNESS SHOWN IN TABLE ARE STANDARD FOR THE ABOVE DESIGN CRITERIA. MAXIMUM SLAB THICKNESS IS 406mm
7. MAXIMUM INTERNAL IS LIMITED BY THE MAXIMUM SHIPPING HEIGHT AND MASS. MINIMUM INTERNAL HEIGHT MAY BE ZERO. A SLAB WILL BE PROVIDED.
8. 305 X 305 HAUNCH IS AN OPTION.

CONCRETE

9. MINIMUM CONCRETE STRENGTH 40MPa.

REINFORCING STEEL

10. REINFORCING STEEL CONFORMS TO THE FOLLOWING LATEST CSA OR ASTM STANDARDS:
 ASTM A185 WELDED STEEL WIRE FABRIC FOR CONCRETE REINFORCEMENT
 ASTM A497 WELDED DEFORMED STEEL WIRE FABRIC FOR CONCRETE REINFORCEMENT
 CSA W186-M WELDING OF REINFORCING BARS IN REINFORCED CONCRETE CONSTRUCTION
 CSA G30.18-M DEFORMED REINFORCING BARS SHALL BE 400W PER LATEST
11. CLEAR COVER TO REINFORCING STEEL
 MESH: 40 mm +/- 5 mm
 REBAR: 50 mm +/- 10 mm

INSTALLATION

12. BACKFILL AND COMPACTION TO OWNER'S REQUIREMENT
13. RESPONSIBILITY FOR CONSTRUCTION REVIEW, ADEQUACY, AND SUITABILITY OF EXCAVATION, DEWATERING, SHORING, HANDLING EQUIPMENT, AND SOIL STABILITY BY OTHERS

BUOYANCY

14. WHEN APPLICABLE, EXTENDED BASE IS REQUIRED FOR ANTI-BUOYANCY.

DESIGN CONSIDERATION

15. SLAB OPENING: Ø685 OR 750 X 1000 OR 800 X 1200 OR 800 X 1800. LARGER OPENING OR RECTANGULAR OPENING MAY BE ACCOMMODATED.
16. CAST-IN TRANSITION RISER IS AVAILABLE.
17. WALL OPENING: CIRCULAR, UPSIDE DOWN DOGHOUSE HOLE
18. WALL OPENING MAY BE FORMED OR CORED DEPENDS ON APPLICATION

OTHER DESIGN NOTES

19. MONOBOX ARE BUILT DRY CAST (DC) OR WET CAST (WC).
20. STANDARD MONOBOX COMPONENT HAS TONGUE/GROOVE JOINT. JOINT HEIGHT IS 40mm FOR 240mmØ X 1800mm AND 102mm FOR ALL OTHER SIZES. 25mm BUTYL RUBBER TO BE SUPPLIED BY CON CAST PIPE AND INSTALLED ON SITE BY OTHERS. SPECIAL JOINT OR WATER PROOFING ARE AVAILABLE UPON REQUEST.
21. MONOBOX STRUCTURE COMES WITH STANDARD 16" HOLLOW ALUMINUM STEP(S) CONFORMED TO OPSD405.010 SPACED AT 300. OTHER TYPE OF STEP(S) OR LADDER ARE AVAILABLE UPON REQUEST.
22. CAST-IN DAYTON SUPERIOR P50 SWIFT LIFT ANCHORS OR EQUIV. ARE STANDARD DEVICE FOR HANDLING AND INSTALLATION.
23. CAST-IN INSERTS FOR CAST-IN-PLACE COMPONENTS SUCH AS THRUST BLOCK ARE AVAILABLE UPON REQUEST.
24. CAST-IN LIFTING HOOKS OR THREADED INSERTS FOR INTERNAL LIFTING ANCHORS ARE AVAILABLE UPON REQUEST.
25. CONTACT CON CAST ENGINEERING FOR DESIGN BEYOND THE DESIGN CRITERIA AND LIMITATION LISTED IN THIS DOCUMENT

FINAL DESIGN FOR APPROVAL AND MANUFACTURING

26. STANDARD REINFORCEMENT FULFILLS THE DESIGN CRITERIA.
27. FINAL DESIGN OF MONOBOX INCLUDING, BUT NOT LIMITED TO, STACKING, ADDITIONAL REINFORCING, CUSTOMIZATION WILL PRESENT IN SHOP DRAWING PACKAGE.

ALL DIMENSIONS ARE IN mm DRAWINGS ARE NOT TO SCALE		CON CAST PIPE (CCP) STANDARD DRAWING					
		STD. CCP ENG GUIDE B.8.1.5				PART MONOBOX-GUIDE	
		MONOBOX - CHAMBER APPLICATION DESIGN GUIDE					
3							
2	NOTE 1-4, 8, 10, 20	SW	22MAY15				
1	NEW RELEASE	SW	1MAY2014	DRAWN BY SW	CHECKED BY	DATE 22MAY15	FILE MONOBOX Rev4
REV.	DESCRIPTION	ENG.	DATE				PAGE 2 OF 2